



ECOWAVE ABSORB

The Absorbent recycling system stores, distributes, recycles and recovers the waste. It separates the soiled absorbent from the reusable one. Working with Fibercan+ absorbent refills, it enables instant absorption.

Mobile and user-friendly, it has all the necessary tools to deal with all types of spillages.



Absorbent refill:
FIBERCAN+

Technical characteristics

Dimensions of the station	1119 x 796 x 651 mm (closed lid)
Dimensions of the sifting grid	350 x 225 mm Opening rate : 58% Size of the perforations : 4 mm
Weight without option	24 kg
Material	MDPE
Wheels	2 polyurethane tyre pivotal wheels + 2 recycable rubber tyre fixed wheel
Mobility	On 4 wheels or 2 wheels
Storage tank volume	45 litres
Waste tank volume	18 litres
Storage space for the consumables	2 cans/sprays + 1 aerosol can compartment
Bottom external compartment	395 x 196 x 520 mm Capacity : 1 absorbent refill or 200 absorbent pads
Included parts	Hand scoop, broom, waste collecting tray
Scoop compartment	Magnetized clip, 9kg strength
Available options	Large shovel, paper roll support, perforated tray, external tray for absorbent pads

Scheme of the cart

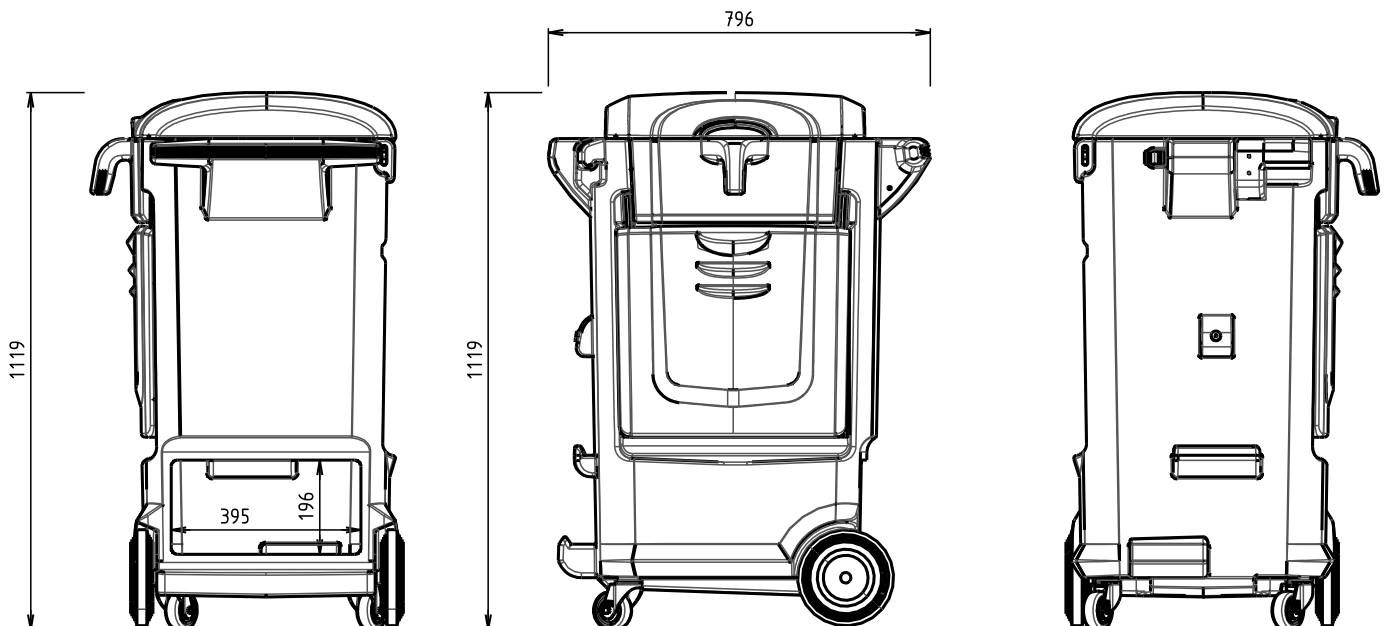

Technical description



EASY MAINTENANCE

Absorbent container and removable waste collection tank



STORES AND DISTRIBUTES

Recyclable and reusable absorbent



ALL-IN-ONE

Quick access to all the tools



ECONOMICAL

Minimise consumption



ULTRA-MOBILE

Enable to come close to the spill



SIFTING BY VIBRATION

Separate the soiled absorbent from the reusable one



WASTE COLLECTION

User-friendly maintenance

3D views



Removable trap easing the access to the absorbent



Quick access to all the tools

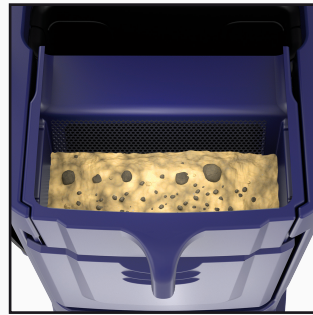

Sifting system



Waste collection

Instructions

